



**For 12mm to 21.5mm Glass and 0.74kN/m<sup>2</sup>**





**KT-Side-Fix-Channel**  
3m Lengths (p/pm)  
Anodized Aluminium



KT-12MMGLASS-KIT
KT-13.5MMGLASS-KIT
KT-15MMGLASS-KIT
KT-17.5MMGLASS-KIT
KT-19MMGLASS-KIT
KT-21.5MMGLASS-KIT

Each glass kit  
included relevant  
top-bead rubber

**KT-Glass-Kit**  
3m Packs - P/P/M  
Wedges / Bolts/ Bars/ Rubbers



**KT-Side-Cladding**  
3m Lengths (p/pm)



**KT-Bottom-Cladding**  
3m Lengths (p/pm)



**KT-Bead-Strip**  
3m Lengths (p/p/m)  
Anodized Aluminium



**KT-Spanner**  
(Recommended 2 per project)



**KT-EndCap-Side-L/H**



**KT-EndCap-Side-R/H**



**KT-Dowel-Connect**  
(Pack of 2)



## Side Fixed Onto Concrete

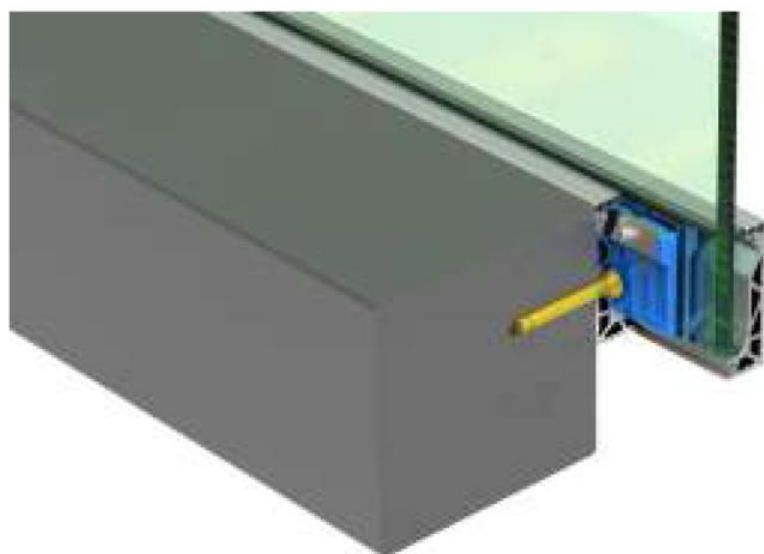

Test Method

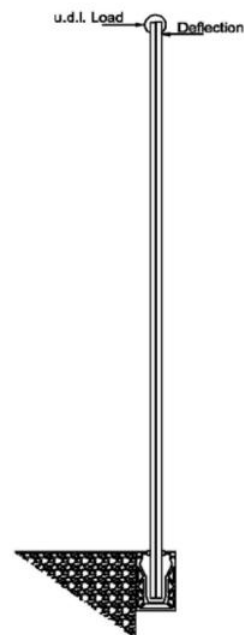

Fixing and

Glass Type	Horizontal U.D.L. kN/m	Height mm	Deflection mm
15mm Toughened, Heat Soaked	0.36	1100	11.65
15mm Toughened, Heat Soaked	0.71	1100	25.00
19mm Toughened, Heat Soaked	0.74	1093	15.38
19mm toughened, Heat Soaked	1.05	1093	25.10
21.5mm EVA Laminated Toughened Heat Soaked	0.36	1085	8.37
21.5mm EVA Laminated Toughened, Heat Soaked	0.74	1085	18.65
21.5mm EVA Laminated Toughened, Heat Soaked	0.95	1085	25.00
21.5mm Rigid Laminated Toughened, Heat Soaked	0.74	1100	13.20
21.5mm Rigid Laminated Toughened, Heat Soaked	1.00	1100	19.43
21.5mm Rigid Laminated Toughened, Heat Soaked	1.15	1100	25.00

## Side Fixed Onto Steel

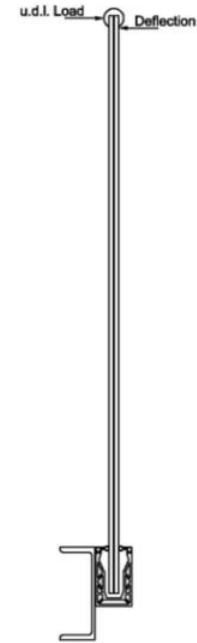

Fixing and Test Method

Glass Type	Horizontal U.D.L. kN/M	Height mm	Deflection mm
15mm Toughened Heat Soaked	0.36	1113	10.35
15mm Toughened Heat Soaked	0.74	1113	24.50
19mm Toughened Heat Soaked	0.74	1101	17.60
<b>19mm Toughened Heat Soaked</b>	<b>0.91</b>	<b>1101</b>	<b>25.00</b>
21.5mm EVA Laminated Toughened Heat Soaked	0.36	1090	8.09
21.5mm EVA Laminated Toughened Heat Soaked	0.74	1090	18.85
<b>21.5mm EVA Laminated Toughened Heat Soaked</b>	<b>0.89</b>	<b>1090</b>	<b>25.00</b>
21.5mm Rigid Laminated Toughened Heat Soaked	0.36	1112	6.31
21.5mm Rigid Laminated Toughened Heat Soaked	0.74	1112	13.13
21.5mm Rigid Laminated Toughened Heat Soaked	1.00	1112	20.50
<b>21.5mm Rigid Laminated Toughened Heat Soaked</b>	<b>1.08</b>	<b>1112</b>	<b>25.00</b>

Red writing indicates maximum loading up to the 25mm maximum deflection as per BS 6180:2011

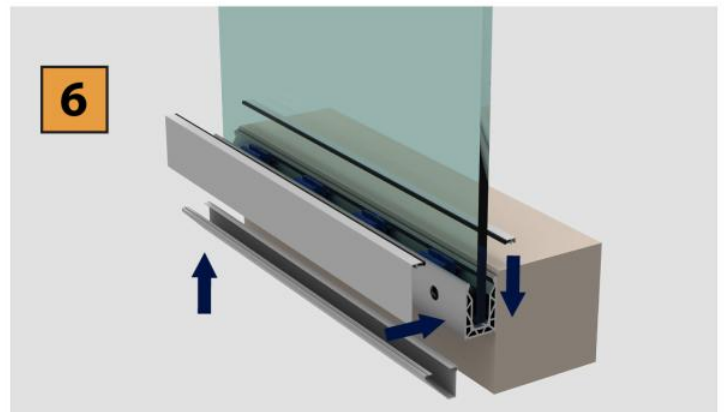
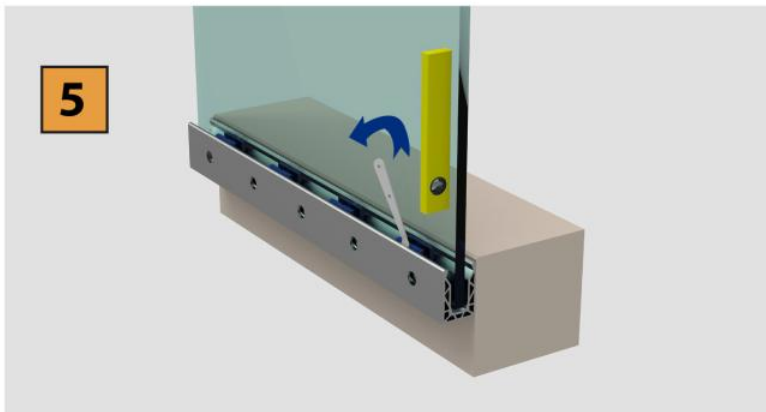
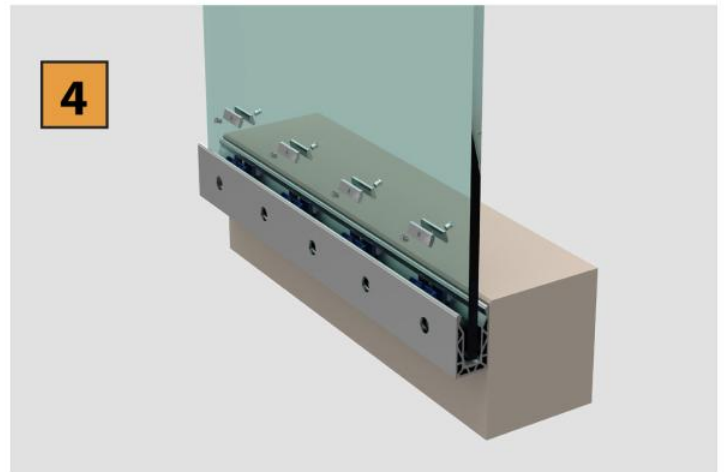
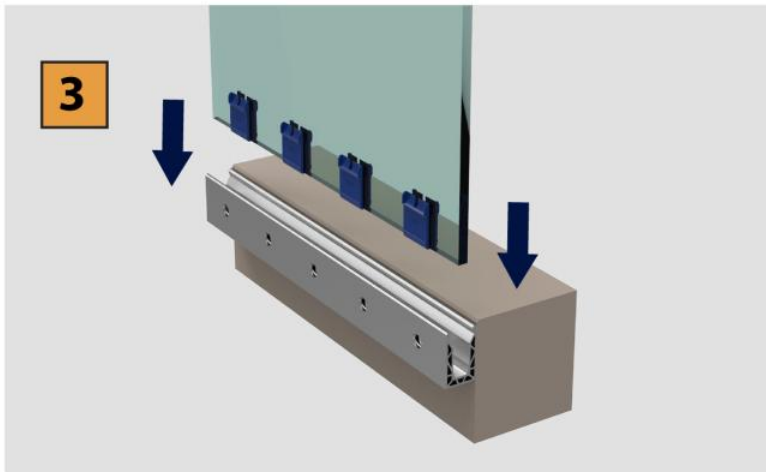
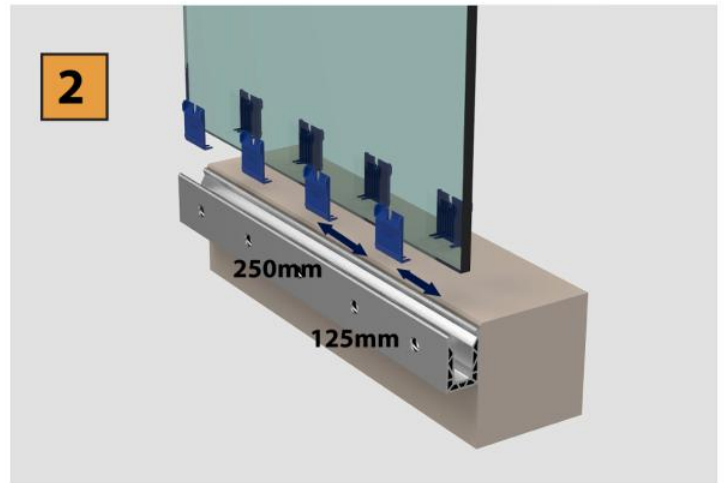
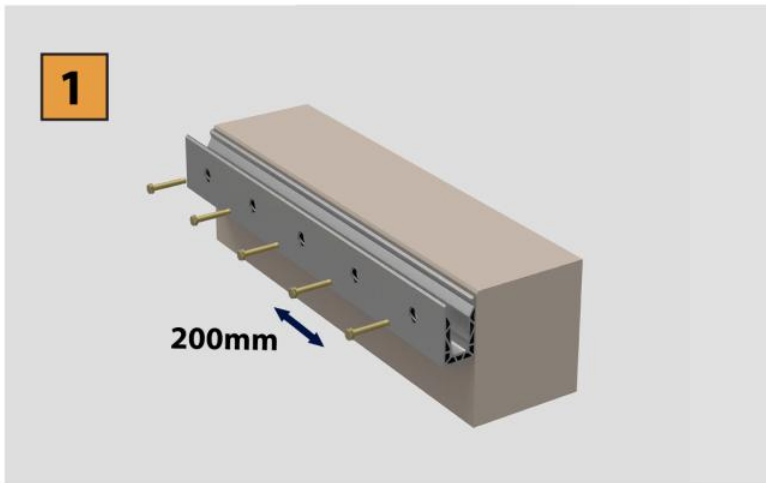
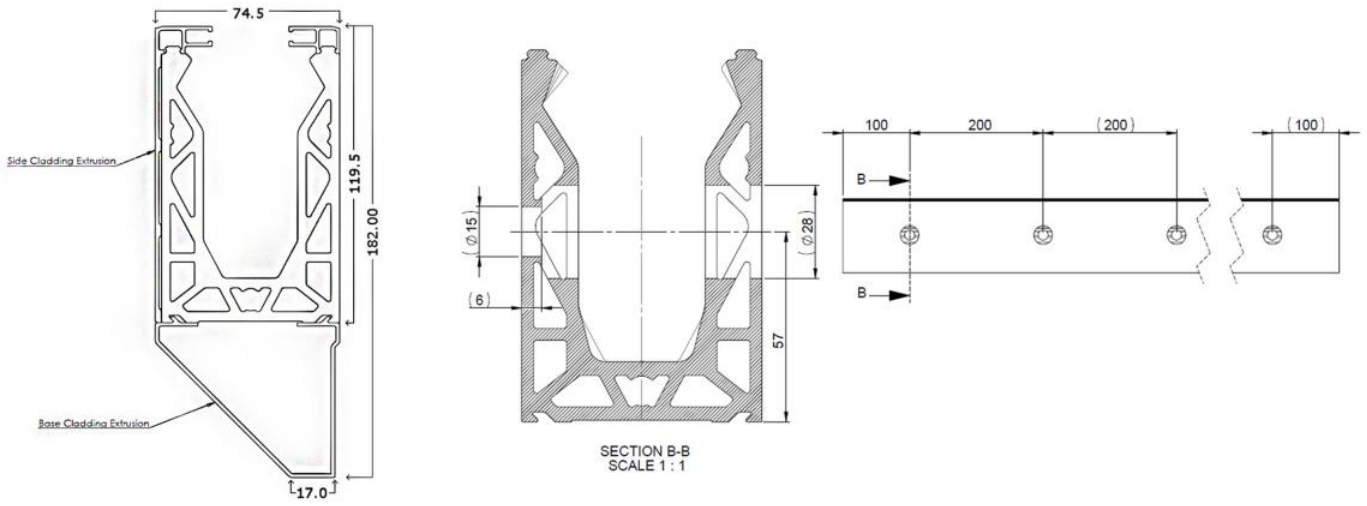

## Fitting Instructions

1. The aluminium base rail should be put into place with the holes marked onto the substrate for drilling, and the aluminium base rail should then be levelled and plumbed up with the use of shims. Once the shoe is plumb and level, the fixings should be tightened up to make the channel rigid. The fixings should be tightened in accordance with the manufactures.

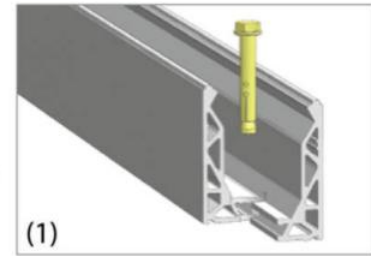

2. The glass slip clamp needs to be placed on the bottom of the glass. This requires lifting the glass off the floor sufficiently to squeeze these on or turning the glass upside down. The slip clamps require spacing according to the glass thickness these are as followed:-

- All glass types require 4 clamps per metre so number one should be in 125mm from the end of the glass and then 250mm thereafter.

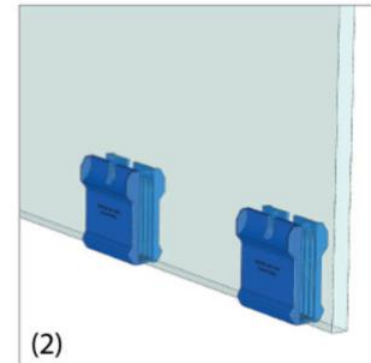

3. Once the glass is fitted into place, you now need to press the clamp bars into the top of each glass slip clamp. These need to be put in the right way for correct and proper fitment – this is shown in the image on the right.

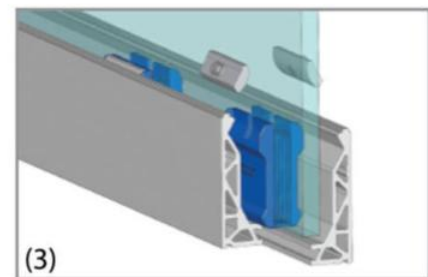

4. Once these are in you now need to place a spirit level on the glass to get the glass plumb. These bolts now need tightening into the channel equally to keep the same pressures on the glass. To achieve this initially make sure they are plumb and level at each end of the glass and tighten. Then tighten the intermediate clamp bars. Once the bolts have pinched they now require an additional quarter to lock the glass in place.



5. The gasket requires feeding into smaller channels supplied. Once these are flush with each end the strip now needs to be clipped onto the top channel. This can be done by either pressing the whole thing on evenly or working from one end which is recommended. Do not stretch the gasket.

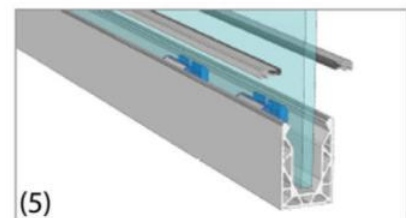

6. Once you are happy everything is in place and the job is complete you need to clean the glass and the channel. We recommend the use of any standard glass cleaner so long as it is not abrasive. We also recommend a soft sponge or cloth again to avoid any risk of scratching.